

# CHEMAT

<b>1. Contents</b>	
<b>2 General</b> .....	1
<b>3 Designated use</b> .....	1
3.1 Limitations of use.....	1
<b>4 Safety instructions</b> .....	1
4.1 General safety instructions.....	1
4.2 Safety instructions for users.....	1
4.3 Special hazards .....	2
4.4 Hazards during maintenance work.....	2
4.5 Identification .....	2
<b>5 Assessment of conformity with RL94/9/EG (ATEX)</b> .....	2
5.1 Special instructions.....	2
<b>6 Transport and storage</b> .....	2
<b>7 Installation instructions</b> .....	3
7.1 Ball Valve installation position.....	3
7.2 Installation in the pipeline .....	3
<b>8 Ball Valve actuation</b> .....	3
8.1 Actuation using a hand lever.....	3
8.2 Operation by use of actuator or gearunit.....	3
<b>9 Repair</b> .....	3
9.1 Changing the ball, ball seat, and body seal with a low-maintenance shaft seal.....	3
9.2 Changing the low-maintenance shaft seal.....	4
<b>10 Spare parts</b> .....	4
<b>Tightening torque table</b> .....	3

## 2. General

- Chemat GmbH is a Pentair International Ltd company and its products are manufactured and distributed exclusively by Pentair Valves & Controls Distribution GmbH.
- These operating instructions do not govern what is contained in the delivery schedule. They cover a variety of different sizes, designs, special features and auxiliary equipment. Hence their content generally extends to cover equipment not included in the contractually agreed delivery schedule. They contain the information necessary for safe and correct installation and operation of the valve in the prescribed manner. If any difficulties are encountered during installation or operation which cannot be solved with the aid of the operating instructions, please contact the supplier/manufacturer for more information.
- We recommend that operating staff be given appropriate training in the operating instructions.



Special attention must be paid to instructions marked with this symbol.

### • Disclaimer of liability

Pentair Valves and Controls Distribution GmbH accepts no liability for any damage or malfunctions resulting from failure to follow the operating instructions and heed safety information.

## 3. Designated use

- The Chemat two piece sampling unit is in two parts and is intended for installation between flanges in the relevant pressure rating.
- Chemat sampling valves are used exclusively for taking samples pressure less, where the size of the blind hole in the ball determines the sample volume.
- The sampling valves can be used for fluids belonging to groups 1 and 2 as defined in appendix II diagram 6 of the PED 97/23/EC, up to and including category III.
- Valves for use with oxygen are identified with a blue dot, sealed in a plastic bag and marked with a warning notice.
- The operating temperature can range from -10°C to +60°C, depending on the bottle adaptor, sample bottle and sealing material.
- A precondition for correct use is that the safety instructions given in section 4 are heeded.

### 3.1 Limitations of use

- The limitations applicable to the use of the valve must not be exceeded at any time.
- The use of the sampling valves in liquids containing solids of a hard consistency is not recommended since this can result in damage to the sealing element and hence leakage of the valve.
- The sampling valves may be used only if it is certain that the valve materials are compatible with the media.

## 4. Safety instructions

### 4.1 General safety instructions

The sampling valve is subject to the same safety regulations as the pipework system in which they are fitted. The additional safety information for the Sampling Valve is indicated in this document.

### 4.2 Safety instructions for the user

It is not the responsibility of the manufacturer, but is incumbent upon the operator to ensure that:

- the sample valves are used only in accordance with their intended purpose, as described in Section 3;
- the pipework system is installed correctly and inspected regularly;
- the valve is installed correctly in the pipework system;
- any actuator that is subsequently fitted to the valve is suitable for the valve and is correctly adjusted to the end positions - especially the CLOSED position - of the sample valve;
- normal flow rates are not exceeded when in permanent operating mode and abnormal operating conditions (oscillations, cavitation, water hammer, etc.) do not arise;
- no sample valve is used outside its permitted pressure/temperature range;



Failure to observe this precaution could put the user at risk and result in damage to the pipework system.

- sample valves that are used at operating temperatures of > +50°C and < -10°C must be insulated to avoid possible injuries;



Failure to observe this precaution could put the user at risk.

- the valve is operated and maintained by competent personnel.

### 4.3 Special hazards



If the valve is used in hot media or liquids in which exothermic reactions can occur, ensure that the surface of the valve does not become a source of danger for people and the surrounding atmosphere.

- Make sure that the operating temperature will not create an ignition when used in dusty environments.

Before taking a sample, ensure that the sampling bottle is empty and securely connected to the valve.

### 4.4 Hazards for maintenance work



The valve shaft is sealed with a gasket. Before the packing bolt is loosened or completely unscrewed, the pressure in the pipeline must be fully depressurized so that none of the medium can leak on to the gasket.



Before the sampling valve is removed from the pipeline, the pipeline must be completely depressurized so that the medium does not escape in an uncontrolled fashion.



When the valve is opened and dismantled, it is still possible that a few drops of medium may leak from dead spaces (even unpressurized). Appropriate safety measures must be put in place. Failure to observe this precaution could put the user at risk.

Suitable tools must be used for installation and maintenance work, especially when dealing with plant in environments where there is a risk of explosion.

### 4.5 Identification

Manufacturer:	CHEMAT
Type:	CAPRO
Nominal diameter:	DN
Design pressure:	PN
Material:	e.g. 1.4571
Batch no.:	e.g. H5426
Serial no.:	e.g. 07488
Year of manufacture:	(P = 2003; Q = 2004; R = 2005)
Conformity <sup>1)</sup> :	CE
Identification no. <sup>1)</sup> :	0685 (Nominated body in accordance with PED 97/23/EC: DEKRA)

#### Note:

1) from DN32

## 5. Assessment of conformity with RL94/9/EG (ATEX)

An assessment of the ignition hazard in accordance with DIN EN 13463-1:2001 has been carried out. No potential sources of ignition were identified in relation to the sampling valves. This means that the valves do not fall within the scope of Directive 94/9/EC (ATEX) and hence do not need to be labelled either.

The use of the sampling valves in areas in which explosive atmospheres may arise is therefore permitted, within the scope of their designated use.

### 5.1 Special instructions

All the metallic parts of the sampling valves, including the ball, are electrically connected to each other (resistance <106 Ohms). The sampling valves can therefore be used for all inflammable media and in explosive atmospheres of any kind.

Nevertheless, we would like to point out that the sampling valves should be included in measures taken to equalize potential, just in case the use of particular media and particular flow rates should cause a potential to arise (through static charging). This depends on the operating conditions and is therefore the responsibility of the operator.

## 6. Transport and storage

The valves should be stored in a dry environment protected from the weather at a temperature of between -20°C and +65°C.

To eliminate the risk of damage during loading and unloading, the valves should be moved by hand or with the use of a suitable lifting tool. The valves should be protected against external force (impact, shock, vibration) during transport. After a long period of storage, we recommend carrying out a pressure test before bringing the valve into service.

The flanges are provided with protective caps in order to prevent the ingress of dust and dirt as well as to avoid damage to the sealing surfaces during transport and storage. The protective caps must only be removed just before installation of the valve in the pipeline.

### 7. Installation instructions

#### 7.1 Sampling Valve installation position

The sampling valve can be installed at any position in the pipeline, with the bottle vertical positioned below the valve. The direction of flow through the valve is not important.

#### 7.2 Installation in the pipeline

Once the protective cap has been removed, care should be taken that no contaminants get inside the sampling valve.

The valve can be installed directly in the pipework system. When doing so, it should be aligned with and fitted into the pipeline in such a way that it can be mounted without using force.

### 8. Ball Valve actuation

#### 8.1 Actuation using a hand lever

Sampling valves up to DN 100 are supplied with hand levers as standard, where the position of the hand lever also indicates the position of the ball cavity. The valve is closed by turning the lever clockwise. Sufficient clearance to allow operation of the sampling valve should be provided.

#### 8.2 Operation by use of actuator or gearunit

On CAPRO sampling valves, the mounting flange for drives is designed to be compatible with DIN/ISO 5211. The torques specified in the catalogue page must be taken into account when dimensioning the operator.

#### Tightening torques for the housing bolts and nuts on the CAPRO 550/650

Bolt material: A2-70/A4

PN	DN	Thread	Tq (Nm)
40	15	M8	20
	20	M8	20
	25	M8	20
	32	M8	20
	40	M 10	35
	50	M 12	55
16	65	M 10	35
	80	M 12	55
	100	M14	80

### 9. Repair

#### 9.1 Changing the ball, ball seat, and body seal with a low-maintenance shaft seal

9.1.1 Set the sampling valve to its open position and unscrew the housing bolts (17).

9.1.2 Close the sampling valve and remove the ball seats (4), body seal (12), ball (3), and ball seat (4) from the housing.

9.1.3 The antistatic spring should be inspected when carrying out repair work. Any contaminants and/or deposits should be removed. Examine the spring for damage and replace if necessary.

9.1.4 Renew defective parts and assemble in reverse order.

9.1.5 Once assembly is finished, a functional check and leakage test should be conducted. In the event of leakage in the passage, re-assemble. If leakage occurs at the control shaft, tighten the packing bolt (7) until it no longer leaks. Renew the cup spring if necessary.

See the table for the tightening torques of the housing bolts.

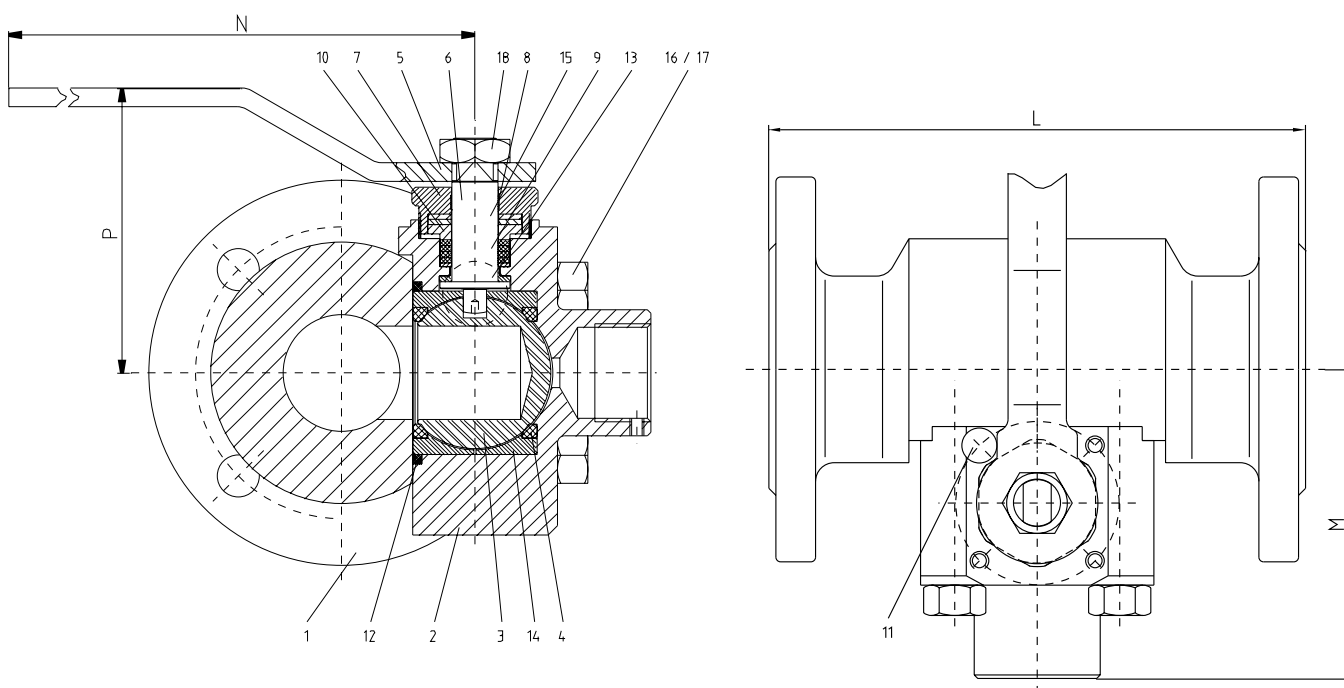

## 9.2 Changing the low-maintenance shaft seal

- 9.2.1 Remove the sampling valve as described in Section 9.3.
- 9.2.2 Remove the hand lever (5) by unscrewing the nut (18) and remove the stop (11).
- 9.2.3 Remove the packing bolt (7) with the guide sleeve (8). Take out the shaft (6) inwards through the main part of the housing.
- 9.2.4 Remove and renew defective gasket (9), including the shaft bearing (13). (In many cases, it is merely necessary to replace the TF4220 packing washers. The metal washers can be reused.)
- 9.2.5 Insert the shaft with the new shaft bearing via the inside of the housing, taking care not to damage the new gasket.
- 9.2.6 Screw in the packing bolt (7) and tighten it up to the stop, then loosen it off a 1/4 turn. (This allows for emergency resetting.)
- 9.2.7 Fit the hand lever (5).
- 9.2.8 With the shaft in the closed position, fit the ball (3) and seals as described in section 9.3.
- 9.2.9 Once the shaft has been replaced, a functional check and leakage test should be conducted.  
If leakage occurs at the control shaft, tighten the packing bolt (7) until it stops leaking.  
Renew the cup spring if necessary.

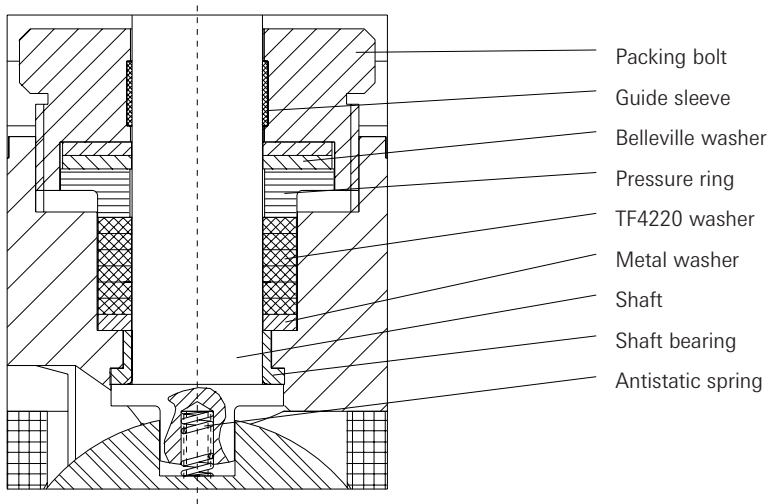

## 10. Spare parts

Only spare parts from Pentair Valves & Controls Distribution GmbH may be used.  
Pentair Valves & Controls Distribution GmbH does not accept any liability for damage caused by the use of non-original spare parts.

Please give the following information when ordering spare parts.

- Serial no.
- Ball valve model
- Nominal diameter