



### MAGNATEX® MAXP Series Specifications

Maximum Flow	2000 GPM
Maximum Head	470 FT
Liquid Temperature	-150°F – 800°F
Maximum Power	up to 200 HP
Connections	150lb RF std. or optional 300lb RF ANSI Flanges
Bearing	SiC, SiC-X optional for upset or Dry-run Conditions
Maximum Working Pressure (standard)	285 psig
Impeller	Enclosed
Speeds	up to 3550 rpm
Magnets	Neodymium or Samarium Cobalt for High Temperature
Motor	NEMA or IEC Frame
Secondary Containment	Optional
Steam Jackets	Optional
External Flush	Optional
Re-circulated Flush & Vent	Optional
Vortex Breakers	Optional for Improved Solids Handling
Centerline mounted	Optional

## Magnetic Drive Sealless ANSI Process Pumps

### MAGNATEX® MAXP Series

The MAXP Series of pumps has been designed to conform to ANSI B73.3 dimensional standards. The pumps are extremely rugged, which makes them ideal for rigorous duty in the chemical and petrochemical industries.

#### Magnatex MAXP pumps have the following design features:

- Straddle-mounted inner magnet system with bearings on both sides of the magnet—this design reduces shaft and bearing loads when compared to our competitors' overhung, cantilevered, inner magnet designs
- Slip-fit construction, which allows easy on-site maintenance with no special tools or fixtures required
- Large internal flow paths, which means the pumps can easily handle 1% solids @ 500µ and up to 8% solids @ 100µ. Optional baffle-plated rear casing enables enhanced solids handling capability. Optional proprietary self-cleaning strainer technology enables us to handle even higher solids percentages if necessary
- No expensive mechanical seals; eliminates costly shutdowns and repairs, which helps eliminate "Reportable Release" issues
- Safely handles toxic, noxious, corrosive or high-temperature liquids with increased safety to personnel and the environment
- Special high-temperature construction is available to handle up to 800°F
- Several dual containment systems are available that virtually eliminate any leakage to the environment when handling extremely hazardous chemicals

#### Materials of Construction:

- 316SS
- Alloy 20
- Monel
- 304SS
- Alloy B & C
- Titanium

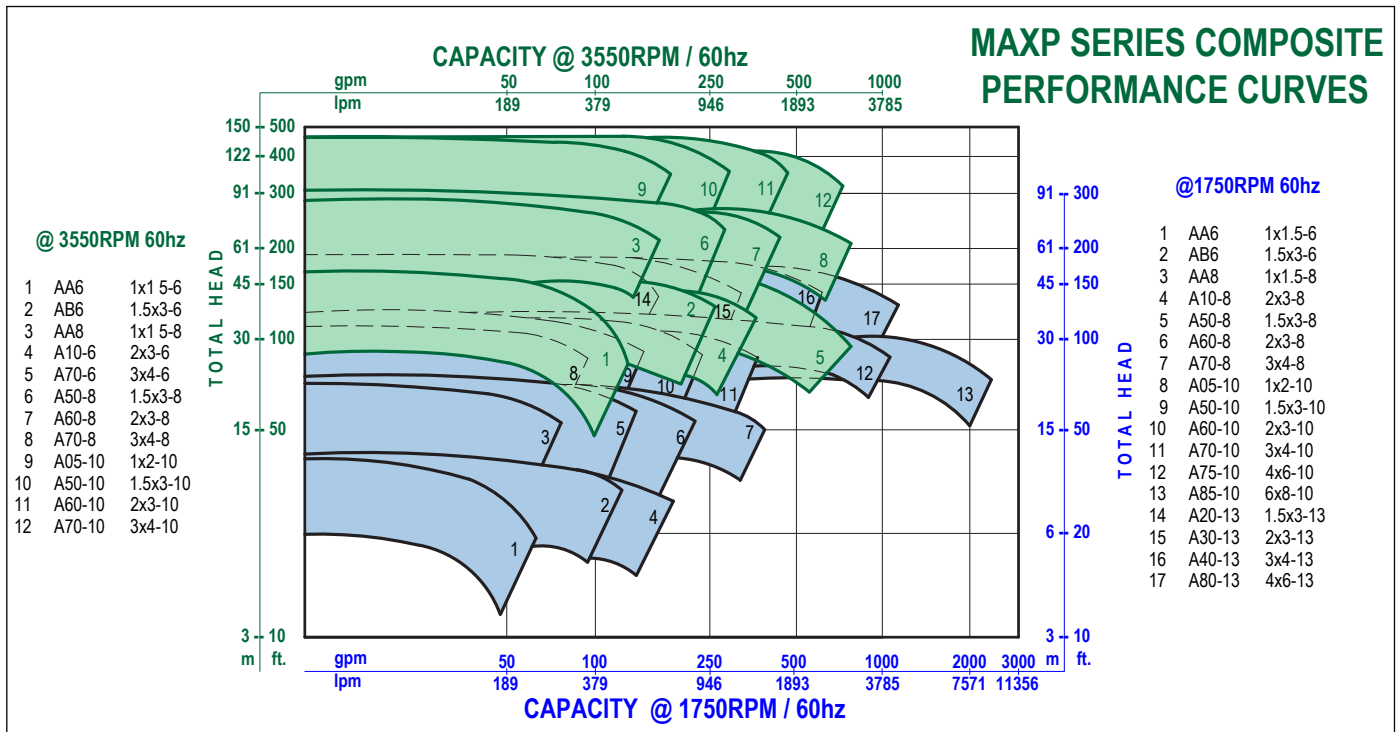

ANATOMY OF THE ULTIMATE MAGNETIC DRIVE PUMP

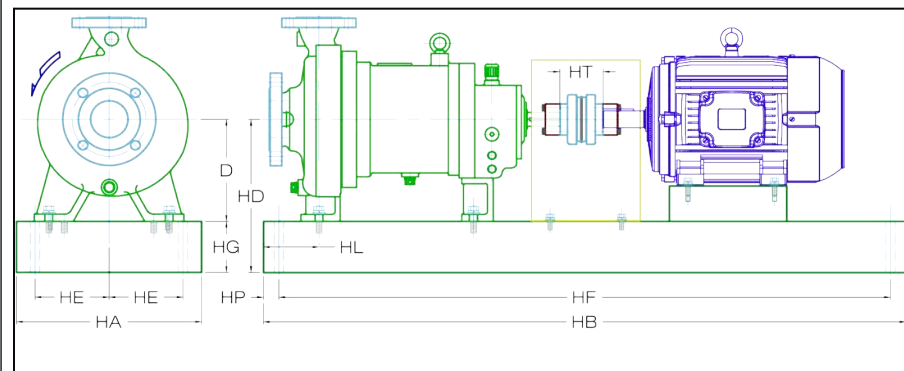
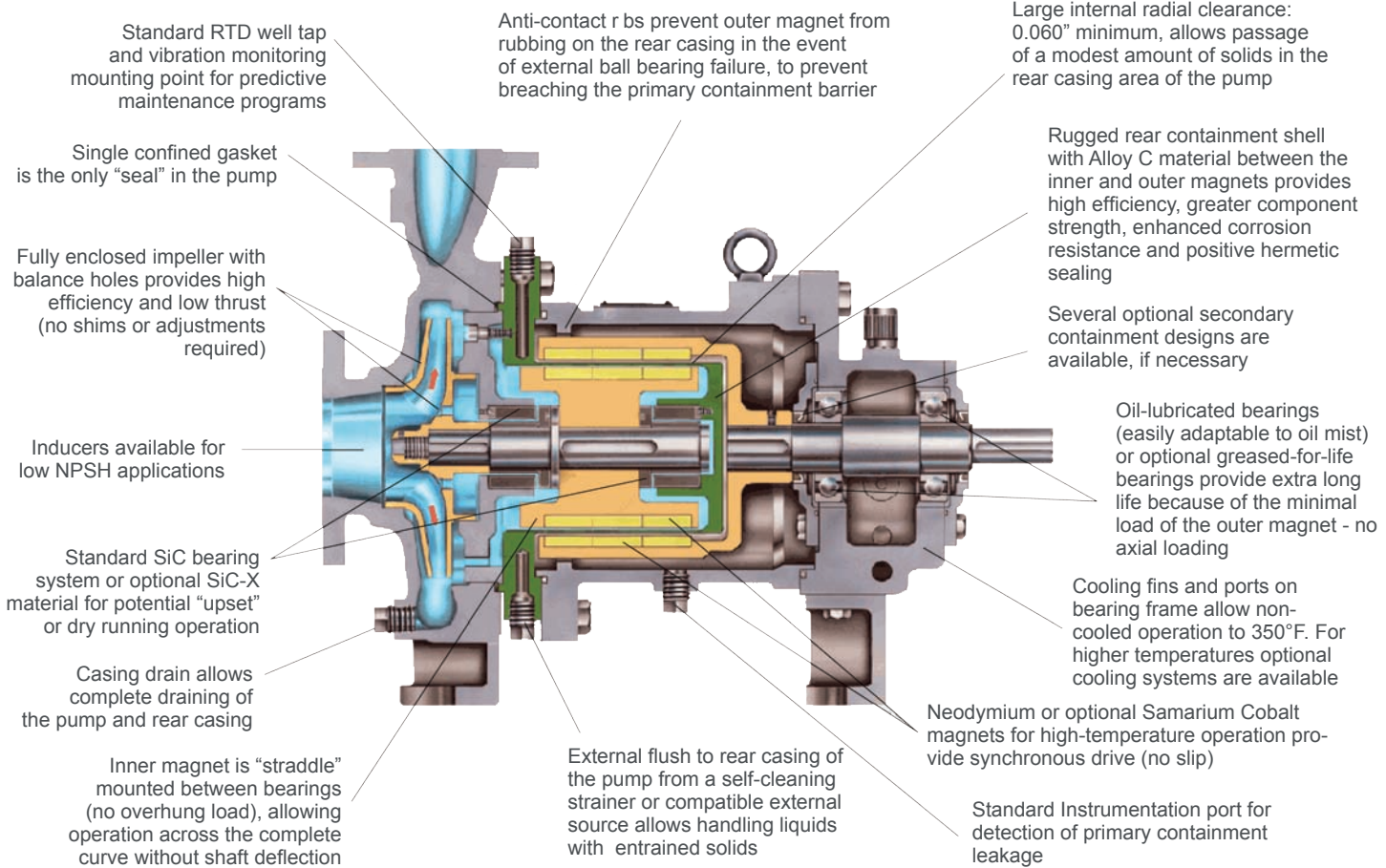

CONDUIT BOX SHOWN FOR ILLUSTRATION ONLY  
REQUIRED LOCATION MUST BE SPECIFIED

**MAGNATEX<sup>®</sup>**  
Pumps, Inc.

DIMENSIONAL DRAWING  
MAXP SERIES ANSI PUMP

DRAWN BY: B VALENTIN    DATE: 08/06/10    SCALE: NTS    PAGE: 1 OF 1

DD-MAXP SERIES

NOT FOR CONSTRUCTION

MAGNATEX MAXP SERIES ANSI BASEPLATE DIMENSIONS

NEMA Frame	Baseplate No.	HA MAX.	HB	HT	HD MAX.				HE	HF	HG MAX.	HH	HL	HP
					D=5.25 [133]	D=8.25 [210]	D=10 [254]	D=14.5 [368]						
184T	139	15 [381]	39 [991]	3.5 [89]	9 [229]	....	....	....	4.5 [114]	36.5 [927]	3.75 [95]	0.75 [19]	4.5 [114]	1.25 [32]
256T	148	18 [457]	48 [1219]	3.5 [89]	10.5 [267]	....	....	....	6 [152]	45.5 [1156]	4.13 [105]	0.75 [19]	4.5 [114]	1.25 [32]
326TS	153	21 [533]	53 [1346]	3.5 [89]	12.88 [327]	....	....	....	7.5 [191]	50.5 [1283]	4.75 [121]	0.75 [19]	4.5 [114]	1.25 [32]
184T	245	15 [381]	45 [1143]	3.5 [89]	....	12 [305]	13.75 [349]	....	4.5 [114]	42.5 [1080]	3.75 [95]	0.75 [19]	4.5 [114]	1.25 [32]
215T	252	18 [457]	52 [1321]	3.5 [89]	....	12.38 [314]	14.13 [359]	....	6 [152]	49.5 [1257]	4.13 [105]	0.75 [19]	4.5 [114]	1.25 [32]
286T	258	21 [533]	58 [1473]	3.5 [89]	....	13 [330]	14.75 [375]	....	7.5 [191]	55.5 [1410]	4.75 [121]	1 [25]	4.5 [114]	1.25 [32]
365T	264	21 [533]	64 [1626]	3.5 [89]	....	13.88 [353]	14.75 [375]	....	7.5 [191]	61.5 [1562]	4.75 [121]	1 [25]	4.5 [114]	1.25 [32]
405TS	268	26 [660]	68 [1727]	3.5 [89]	....	14.88 [378]	14.88 [378]	....	9.5 [241]	65.5 [1664]	4.75 [121]	1 [25]	4.5 [114]	1.25 [32]
449TS	280	26 [660]	80 [2032]	3.5 [89]	....	15.88 [403]	15.88 [403]	....	9.5 [241]	77.5 [1969]	4.75 [121]	1 [25]	4.5 [114]	1.25 [32]
286T	368	26 [660]	68 [1727]	5 [127]	....	....	....	19.25 [489]	9.5 [241]	65.5 [1664]	4.75 [121]	1 [25]	4.5 [114]	1.25 [32]
405T	380	26 [660]	80 [2032]	5 [127]	....	....	....	19.25 [489]	9.5 [241]	77.5 [1096]	4.75 [121]	1 [25]	4.5 [114]	1.25 [32]
449T	398	26 [660]	98 [2489]	5 [127]	....	....	....	19.25 [489]	9.5 [241]	95.5 [2426]	4.75 [121]	1 [25]	4.5 [114]	1.25 [32]

In inches [millimeters]

COPYRIGHT 2010 MAGNATEX PUMPS, INC.



3575 West 12th Street Houston, TX 77008  
 tel: 713.972.8666 toll free: 866.MAGPUMP fax: 713.972.8665  
 www.magnatexpumps.com