

KTM



Section 1 - Storage

1.1. Preparation and preservation for storage

All valves should be properly packed in order to protect the parts that are subject to deterioration during transportation and storage on site. In particular, the following precautions should be taken:

- The valves must be packed with the ball in the open position.
- The flange sealing surface (raised face) shall be protected with suitable protective oil.
- The end faces of the valve must be protected with appropriate seal discs.
- The type of packing must be defined in the Customer's Order and be appropriate to ensure safe transportation to the final destination and eventual storage before installation. Wrapping and/or covers should be left in place until just prior to installation.

1.2. Handling requirements

1.2.1. Packed valves

Crates: Appropriate crate handling equipment should be used to prevent damage to crated valves.

Boxes: Handling of valves packed in carton boxes should be done with extra caution, taking specific note to lifting points and the center of gravity.

The transportation of all packed valves and components must be carried out safely and in accordance with all local safety regulations. Pay particular attention to the lifting limits of handling equipment with reference to the overall weight of packed and unpacked valves.

1.2.2. Unpacked valves

- The handling of valves unpacked from its original packing needs to be carried out with additional exterior protection in order to avoid damages to machined surfaces. Use pallets at all times, where appropriate.
- When handling large valves, appropriate tools (brackets, hooks, fasteners, ropes) should be used to secure valves firmly; and lifting loads should be balanced in order to prevent the valves from falling or moving during the handling process.



Caution

- When handling valves, the correct equipment and accessories (slings, fasteners, hooks, etc.) must be sized and selected, taking into consideration the individual and/or overall valves weight indicated in the packing list and/or delivery note.
- Lifting and handling must be made only by qualified personnel. Improper hoisting can cause valve deformation or damage from dropping the valve.
- Do not lift valves by using lifting points or lugs located on the actuator as these lifting points/lugs are for the actuator only.
- Do not lift the valve by its hand-lever as these levers are not designed to take the load of the whole valve. Doing so may cause the lever to break off or be disconnected from the valve, resulting in possible valve damage or injury.
- Avoid lifting over a worker's head or equipment, or any other thing that can possibly be damaged or cause of injury in the event that the lifted load falls off the handling equipment.
- All local safety regulations must be observed and complied with at all times.

1.3. Storage and preservation before installation

The storage of the valves should be in accordance with the following criteria:

- Storage room should be clean and dry.
- The ball must be in the open position and the end faces must be protected with appropriate seal discs.
- Periodical checks have to be carried out in the storage area to verify that the above mentioned conditions are maintained.



Caution

The ball valves are delivered with the ball in the full-open position and should be stored as they are. Keeping the ball in other positions or half-open position for an extended period of time could cause seat leakage.

Note

- Do not place consignment package directly on the ground.
- Do not expose consignment packages to the rain/wind or directly to the sun.
- Storage in an open area for a limited period can be considered only if the valves have appropriate packing (packed in cases covered with vinyl sheets protecting from rain, wind, dust etc, and contents well protected with barrier sacks).
- Store in a dry and well ventilated condition.
- If storage is anticipated for an extended period, the desiccant bags (if supplied) should be changed every 6 months.

Section 2 - Installation

2.1. Preparation before installation

- Remove the valve from the shipping package (box or pallet) with care taken to avoid any damage to the valve and actuator (plus accessories where applicable).
- Before installation, remove the seal discs from the flange. Clean the inside of the valve using an air line that includes an appropriate air-filter. Ensure that there are no solid objects such as pieces of wood, plastic or packing materials within the valve or on the valve seat.
- Confirm that the materials of construction listed on the valve nameplates are appropriate for the service intended for and are as specified. When in doubt contact KTM, or your local Pentair facility.
- Define the preferred mounting orientation with respect to the system pressure. The arrow on the body helps to identify the upstream side (high pressure) and downstream side (low pressure).
- Ensure that all stud bolts and nuts of the body joint are firmly fastened.



Caution

- Verify that the direction of the flow in the line corresponds to the arrow indicated on the valve body. Valves without the arrow are bi-directional.
- See the Actuator User Manual for the actuator preparation.

2.2. Installation Instructions

- Ball valves are normally installed in horizontal pipes with the stem facing up. However, there are no limitations regarding the pipe or stem orientation.
- Unless otherwise recommended by KTM, the valve should be installed with the ball in the open position, to ensure that the seat rings are not damaged during installation.
- Particular care should be taken for valves equipped with “fail-close” actuators.
- For operating temperatures above 200°C (392°F), thermal insulation of the valve body is recommended to protect the actuator/accessories from heat beyond the recommended temperature range.
- Handling and lifting of the valves during installation MUST be performed following the same criteria and instructions described in points 1.2. and 1.3.



Important

- It is recommended to perform pipe flushing before installation of the valve. If this is not possible, the installed valve must be in its open position before flushing takes place.
- When conducting pressure test of the pipe system, the valve should be in a full or half open position. Check for any leakage from the joint flange and gland portion during the pressure test.
- If the piping system is pressurized with water for testing, and if the piping system has been shut down for a long time after testing, the following recommendation should be adopted:
 1. Use corrosion inhibitor with water to pressurize the piping system.
 2. After testing, the piping system should be depressurized and the test water completely drained.
 3. Ensure that the corrosion inhibitor does not leave a residue within the system as the particulates may damage the valve sealing surfaces.



Caution

During the pipe system pressure test, care must be taken not to set the valve in the closed position to avoid overload pressure which may cause seat deformation or seat leakage.

2.3. Valve verification before start-up

- Tighten the gland nut just enough to prevent stem leakage. Over-tightening will decrease packing life and increase operating torque. There is no need to over-tighten the stud bolts/nuts to assure gasket tightness.
- Check the operation of the valve by stroking it to “full open” and “full close”. The valve ball travels clockwise to close.

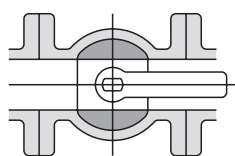

Open position

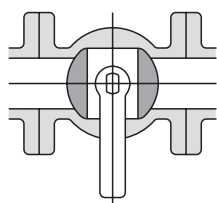

Closed position

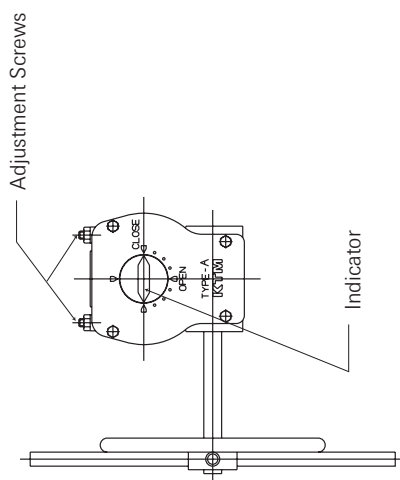

Section 3 - Operation instructions

Either the hand lever or the direction of the parallel flats on the top of the stem indicate the open or closed position of the KTM ball valve. For gear operated valves, the position is indicated by the arrow-indicator (see picture).

Excessive over travel during handle operation may break the lever, injure the operator, and/or deform the stopper or the stem, which may lead to seat leakage.

The following instructions will help provide a satisfactory and long life service.

1. Perform periodic valve verification.
2. In the case of actuated valves, always follow the specific instructions given by the actuator's manufacturer.
3. Never change the setting of torque and/or limit switches set during the final test by the manufacturer.
4. Never change the setting of the mechanical stops of the gearbox.

Locking device (option)

A locking device can be provided to prevent unauthorized operation.

Lock pin dimensions (options)

Unit: mm

Valve nominal diameter (full bore)	Pin dimensions		Nominal pad lock diameter alpha number
	L	d	
15 - 25	25	4,9	1,000 - 25 m/m
40 - 50	31	6,5	1,000 - 25 m/m
65 - 100	39	8	1,000 - 25 m/m
150 - 200	-	-	1,000 - 25 m/m

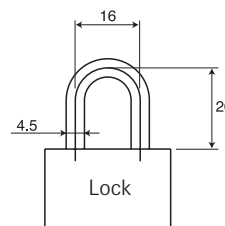
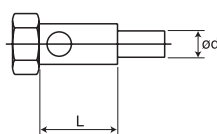

Section 4 - Maintenance

No routine maintenance is required other than periodic inspection to ensure satisfactory operation.

4.1. Gland packing maintenance

If leakage is observed through the gland packing, tighten the gland nuts slowly and evenly until the leakage stops. Do not over-tighten the packing gland nuts. Over-tightening will increase the torque required to operate the valve. Follow the torque table to ensure correct torque used when tightening the gland nut.

Tightening torque for body joint and gland

Class		Body joint				Gland	
		150		300		150 and 300	
Packing material		RTFE or Soft carbon				PTFE	Soft carbon
Valve size		Standard tightening torque* (Nm)					
(mm)	(inch)	Bolt size		Bolt size			
15	1/2"	13 - 18	M8	18 - 23	M8	2	4
20	3/4"	13 - 18	M8	18 - 23	M8	2	4
25	1"	27 - 35	M10	36 - 46	M10	3	6
40	1 1/2"	13 - 18	M8	36 - 46	M10	7	15
50	2"	27 - 35	M10	61 - 77	M12	7	15
65	2 1/2"	49 - 54	M12	93 - 123	M14	16	30
80	3"	49 - 54	M12	93 - 123	M14	16	30
100	4"	75 - 86	M14	148 - 187	M16	19	40
150	6"	118 - 131	M16	385 - 488	M22	19	40
200	8"	220 - 270	M20	492 - 625	M24	32	65

* Standard for Soft (E) seat, Gratitude seat and Metal seat

Replace the gland packing as and when necessary.

- Remove the lever or gear operator, snap ring and stopper.
- Remove the gland bolts and flange.
- Replace the gland packing.

Reverse the procedure.

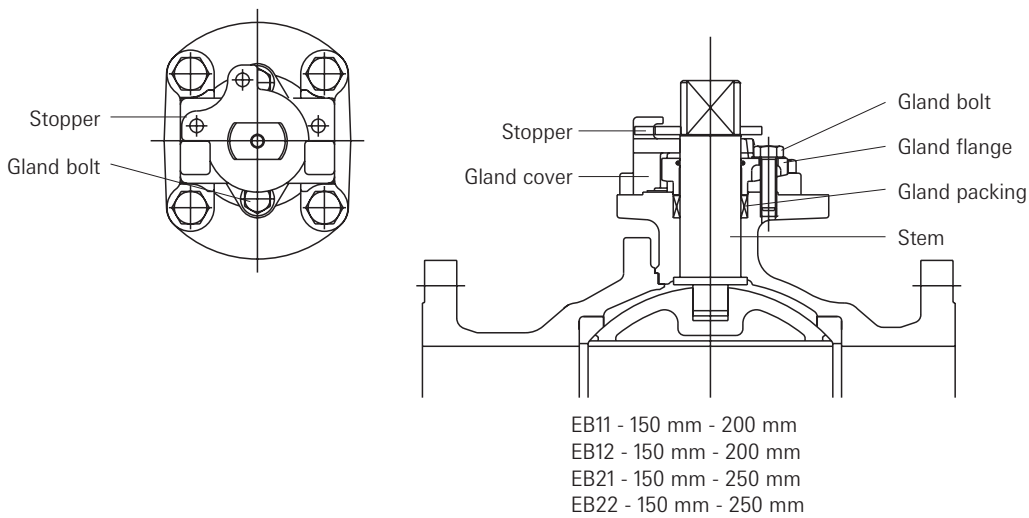
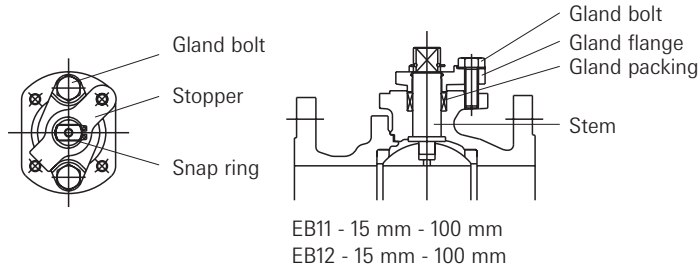

4.2. Body seal maintenance

Any sign of leakage through the body joint seal should be addressed immediately by tightening the stud nuts until the leakage stops. Follow the torque table to ensure the correct torque is used when tightening the gland nut.



Caution

Before removing the valve from the piping, ensure that the system has been fully depressurized and any dangerous fluids have been drained off. Failure to do so may cause serious personal injury and/or damage to the valve.

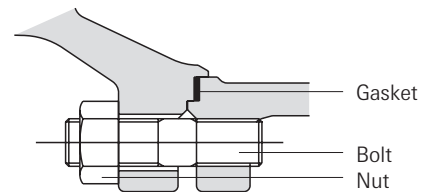

4.3. Valve disassembly

Refer to the respective construction drawing(s) on the following page(s) of the valve(s) when disassembling. Numbers of parts vary slightly depending on the valve size, but the basic structures are identical.

The valve shall be in the half open position.

- Before disassembling the valve, ensure that it has been decontaminated from any harmful gasses or fluids and is within a safe temperature range for maintenance.
- Rotate the ball to a closed position.
- Loosen the hexagon nuts and remove the body cap from the body. The seat and gasket can then be easily removed.
- Remove the ball and seat with care so as to prevent damage to the seal face of the ball.
- Remove the snap ring of the stem with a pair of pliers and remove the gland bolts. Tap the stem head with a plastic hammer and withdraw it towards the interior of the body.

Note

The stem has been designed as “anti-blow out” to improve safety during system operation. This means that the stem cannot be removed from the valve body through the top of the body. It must be removed from within the valve body.

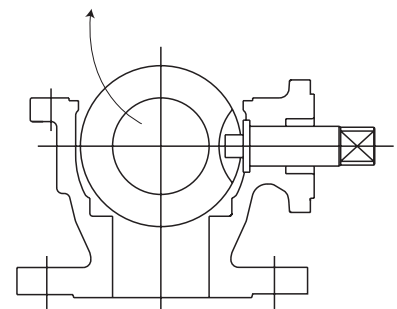

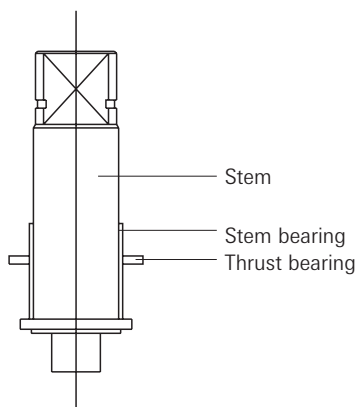

4.4. Valve re-assembly

This work shall be carried out by reversing the aforementioned disassembling procedure. Further, the following points should be noted:

- As shown in the diagram, slip a stem bearing over the stem; set in such a way so that it does not detach from the stem. Then insert it into the gland from the interior of the body.
- Insert the gland packing (see 4.1.) and tighten the gland bolts lightly.
- Since old gaskets occasionally adhere to the body and body cap when the valve is disassembled, the wastes of old gaskets should be completely scraped off and the sealing surfaces should be cleaned before fitting new gaskets.
- When inserting the ball into the valve body, hold the stem in the “SHUT” position as in the case of disassembling and perform insertion in the reversed manner for disassembling.
- Tighten the body cap with the ball in the “SHUT” position. Nuts which face each other are diagonally and uniformly tightened with equal strength, taking care to avoid one-sided tightening.
- Exercise care in re-assembling the valve because its opening and closing vary depending upon whether the correct facing of the stopper (indicating OPEN and CLOSE) is well-set upwards.
- Check the valve operation torque under no load in a dry form before pressure test. Ensure that the measured torque is within range of the standard torque table. In the event the torque is more than the standard torque for Metal and Gratitude seated ball valves, reduce the torque by adding an extra gasket for the body joint.

Valve torque after assembly

Class		150 & 300			
Seat		Soft (E)		Gratite	Metal
Gland Packing		PTFE	Soft carbon	PTFE or Soft carbon	PTFE or Soft carbon
Valve size		Standard valve torque* (Nm)			
(mm)	(inch)				
15	1/2"	2 - 6	5 - 10	max 15	max 7
20	3/4"	3 - 8	6 - 12	max 19	max 7
25	1"	3 - 9	8 - 14	max 23	max 11
40	1 1/2"	6 - 16	19 - 29	max 38	max 20
50	2"	8 - 22	21 - 35	max 55	max 25
65	2 1/2"	14 - 40	39 - 65	max 88	max 35
80	3"	20 - 60	45 - 85	max 125	max 40
100	4"	37 - 110	76 - 149	max 225	max 55
150	6"	104 - 310	170 - 374	max 525	max 100
200	8"	167 - 500	265 - 598	max 1000	max 150

* Torque measured after 2-3 times of operations under no load in a dry form before pressure test

KTM OM-2 Split Body Floating Ball Valves

Installation and Maintenance Instructions

Construction - Soft (E) seat ball valves (1/2" to 1")

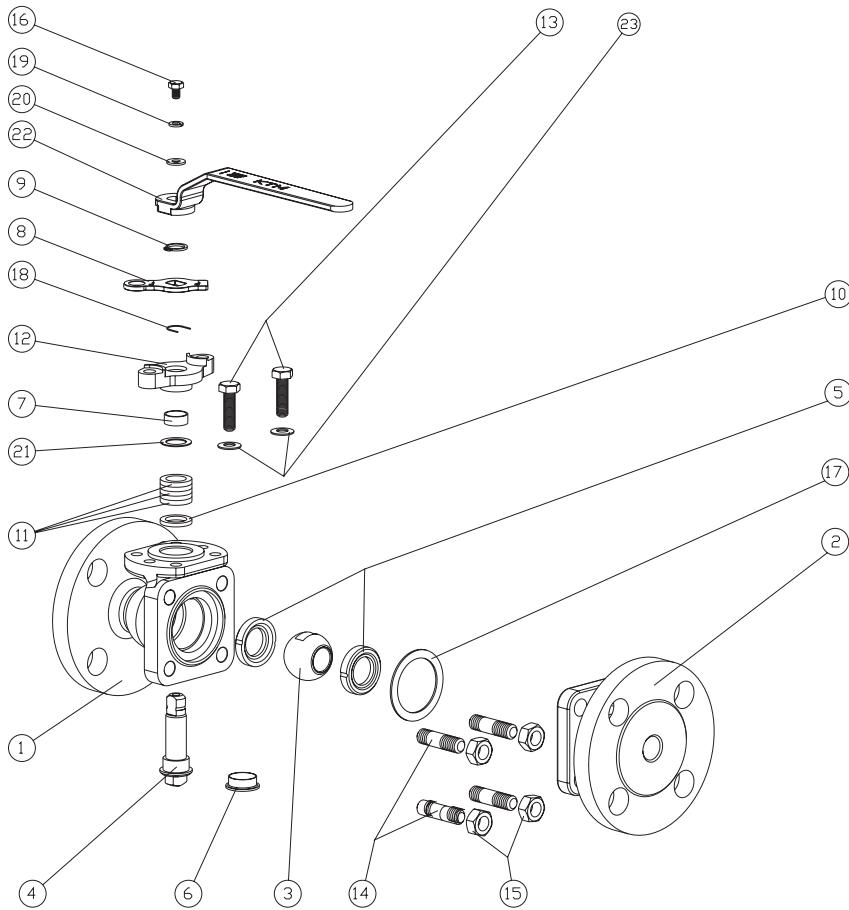

Parts list

No.	Part name	Qty.
1	Body	1
2	Cap	1
3	Ball	1
4	Stem	1
5	Seat	2
6	Stem bearing	1
7	Stem bearing	1
8	Stopper	1
9	Snap ring (C-type)	1
10	Thrust washer	1
11	Gland packing	1 set
12	Gland flange	1
13	Gland bolt	2
14	Stud bolt	4
15	Hexagon nut	4
16	Hexagon bolt	1
17	Gasket	1
18	Spring	1
19	Sp. washer	1
20	Pl. washer	1
21	Pk. washer	1
22	Handle	1
23	Live loading spring	2

Construction - Soft (E) seat ball valves (1-1/2" to 2-1/2")

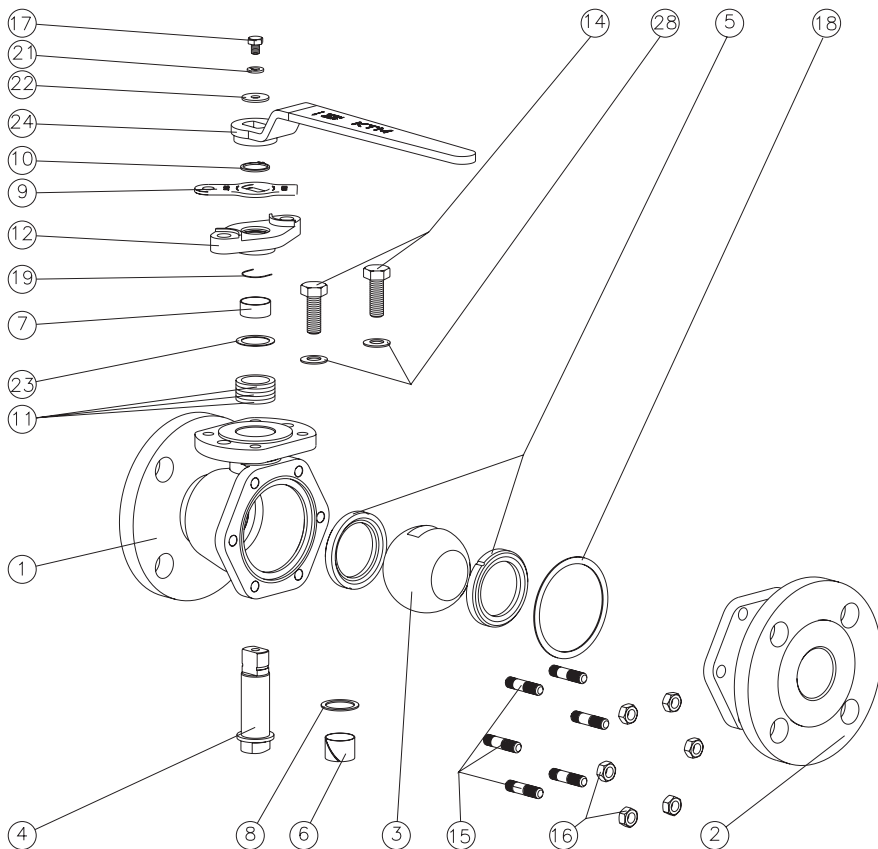

Parts list

No.	Part name	Qty.
1	Body	1
2	Cap	1
3	Ball	1
4	Stem	1
5	Seat	2
6	Stem bearing	1
7	Stem bearing	1
8	Thrust bearing	1
9	Stopper	1
10	Snap ring (c-type)	1
11	Gland packing	1 set
12	Gland flange	1
14	Gland bolt	2
15	Stud bolt	6
16	Hexagon nut	6
17	Hexagon bolt	1
18	Gasket	1
19	Spring	1
21	Sp. washer	1
22	Pl. washer	1
23	Pk. washer	1
24	Handle	1
28	Live loading spring	2

KTM OM-2 Split Body Floating Ball Valves

Installation and Maintenance Instructions

Parts list

No.	Part name	Qty.
1	Body	1
2	Body cap	1
3	Ball	1
4	Stem	1
5	Seat	2
6	Seat retainer	2
7	Inner ring	2
8	Cushion	2
9	Stem bearing	1
10	Stem bearing	1
11	Thrust bearing	2
12	Gland packing	1 set
13	Pk. washer	1
14	Gland flange	1
15	Gasket	1
16	Stud bolt	4-12
17	Hexagon nut	4-12
18	Gland bolt	2
19	Live loading spring	2
20	Stopper	1
21	Sp. washer	1
22	Hexagon bolt	1
23	Handle	1
24	Snap ring	1
25	Pl. washer	1

Construction - Grating seat ball valves

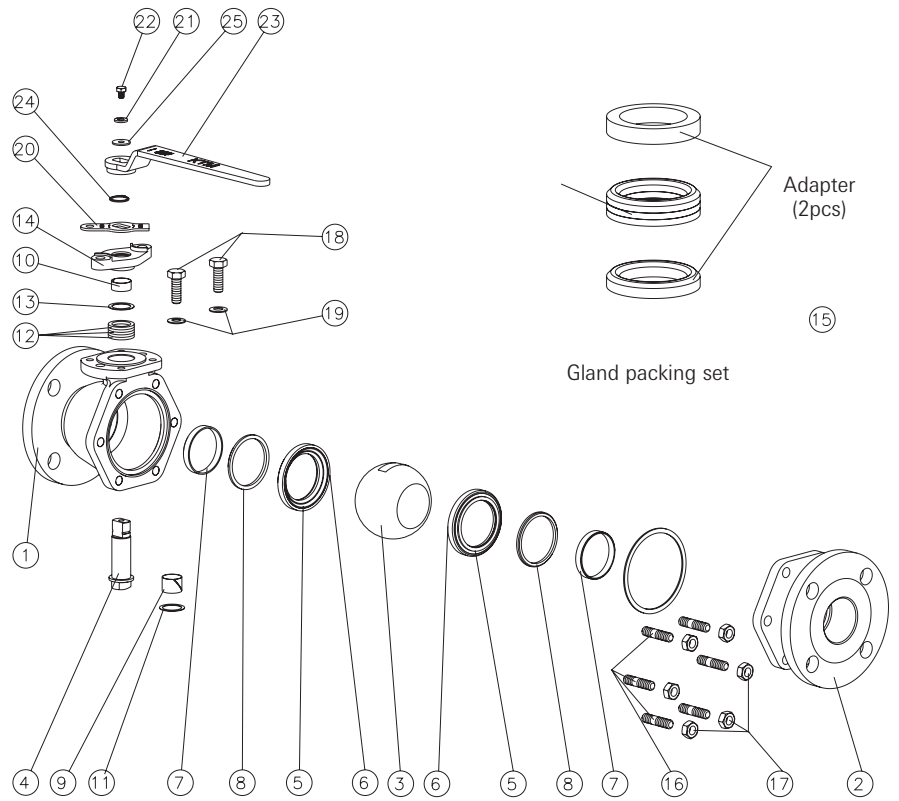

Parts list

No.	Part name	Qty.
1	Body	1
2	Body cap	1
3	Ball	1
4	Stem	1
5A	Seat (A)	1
5B	Seat (B)	1
6	Gasket	1
7A	Stem bearing (A)	1
7B	Stem bearing (B)	1
8	Thrust bearing	2
9	Pk. washer	1
10	Gland packing	1 set
11	Gland flange	1
12	Live loading spring	2
13	Gland bolt	2
14	Stud bolt	4-12
15	Hexagon nut	4-12
16A	Seat gasket (A)	1
16B	Seat gasket (B)	1
17	Spring holder	1
18	Spring	1
19	Stopper	1
20	Hexagon bolt	1
21	Sp. washer	1
22	Handle	1
23	Snap ring	1
24	Pl. washer	1

Construction - Metal seat ball valves

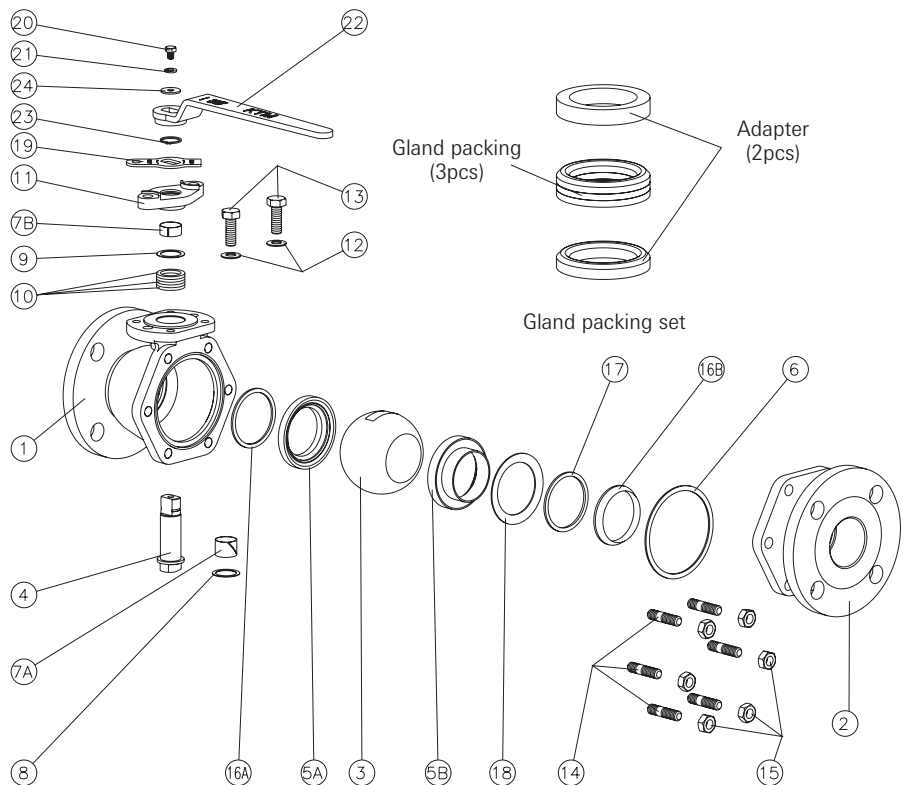

Note

Before assembling, ball and seats shall be lapped with each other.
Fine compound of approximately #1500 is recommended for the lapping.